



**130 KW**

# **DC INVERTER HEAT PUMP 130 KW**

Instruction Manual

**CE**

# SWIMMING POOL HEAT PUMP

## Contents

TO USER .....	2
I.Parameter .....	7
II.Dimensions .....	8
1. Unit installation position.....	8
2. Heat Pump Positioning .....	9
3. Pool Pipe Connecting.....	10
4. Electric wiring .....	11
IV.USE .....	12
1. Display interface .....	12
2. Key function definition .....	12
3. Main interface .....	14
4. Mode selection .....	15
5. Parameter setting .....	16
5.1 Timing switch setting .....	17
5.2 Date and time Settings.....	18
5.3 display setup .....	19
5.4 User set directory .....	21
5.5 WIFI setting .....	26
5.6 Device information query .....	27
V.Maintenance .....	31
1.Note .....	31
2.Debugging And Running .....	31
3.Determine and solve malfunction by below table:.....	32
4.Wiring diagram .....	34

# SWIMMING POOL HEAT PUMP

## TO USER

Dear customers, thank you for using our products.

Here is some matters need attention for you below , as improper operation or unqualified engineering will reduce the service life of equipment, damage the unit, and even cause safety accidents:

### General procedures

1. The unit must be initially started by authorized personnel or under their supervision.
2. In order to better use the equipment, operators need to be training.
3. Operators regularly record the operation data of the unit periodically to provide accurate data and basis for equipment maintenance.
4. The system is filled with high pressure refrigerant. During the installation, operation and maintenance of the unit, It is forbidden to trample, collide and deform pipelines, instruments, valves and joints to avoid leakage of refrigerant.
5. When the heat pump occur failure protection, please find out the reason according to the controller display. Restart the unit after have the solution, otherwise the unit will damage.
6. The refrigerant in the system of the unit is tasteless and non-toxic, but when there is a large amount of leakage in the closed space, it can cause asphyxiation and produce toxic gas in case of fire. When it is found that leakage cannot be stopped, it is absolutely prohibited to fire, and please stay away from the unit, ventilate the scene, inform relevant personnel to cause prevention.

### Installation guide

1. Equipment installation, debugging and maintenance must be operated by professionals.
2. There is obstacle distance requirement for the unit installation. Please refer to the product manual for details.
3. The outlet water pipe of the unit must be installed with a flow switch and connected to the control part of the unit, otherwise the heat exchanger pipe will be damaged by frost crack.
4. The water inlet pipe of the unit shall be equipped with a detachable pipe filter of more than 40 mesh, otherwise the sand particles in the water will wear through the pipe wall of the heat exchanger and damage the unit. Please check and clean water filter monthly.
5. The circulating heated water of the unit must meet the national residential water standard, otherwise, the untreated water will corrode copper pipe and the reduce the heat transfer effect. Please inspect into the water quality of the unit regularly.
6. Please check water system has been cleaned and there is no leakage before the heat pump water side heat exchanger is connected to the water.

# SWIMMING POOL HEAT PUMP

## Operation requirement

1. Don't adjust the set values of parameters of the heat pump (except technical personnel ).
2. After the first start up or long shutdown, check whether the electrical equipment connection is tight; the valves are open before starting and the compressor must be powered on for more than 8 hours before standby heating. Otherwise it will cause irreversible damage to the compressor.
3. When the environment temperature is lower than 0 °C, if do not use the heat pump for a long time, please check the water of unit and system have been drained out or not, otherwise it will easy to frost and damage heat exchanger.
4. Please ensure in and out of the water temperature difference of circulating water pump is between 6 °C or less.

## Electricity safety warning

1. Before electricity-related operations, all power supply must be cut off and anti-static gloves must be worn to avoid serious casualties.
2. The power line must be selected according to the maximum operating current of the unit.
3. Please follow the circuit diagram in the electrical box to wire.
4. When the unit is connected with external power cord, the coil or sheath cannot fall off to prevent power leakage.
5. The unit must be strictly grounded.
6. The power line and signal line must be wired separately, and don't use the same multi-core cable.
7. The three-phase unit is strictly prohibited to operate in reverse phase or absent phase, please check the phase sequence before starting up.

## Winter defrost warning

1. When the ambient temperature is lower than 0 °C in winter, do not turn off the heat pump.  
If the heat pump is turned off more than 1 hour or not used for a long time, please cut off the power supply and drain the water in the heat exchanger to prevent the machine damage from freezing, this situation does not belong to warranty.
2. When the ambient temperature is lower than 0 °C and heat pump is off, please do not cut off power supply. If the heat pump is turned off more than 1 hour or not used for a long time, please cut off the power supply and drain the water in the heat exchanger to prevent the machine damage from freezing, this situation does not belong to warranty.
3. If the heat pump unit is off and in standby mode, the unit with automatic anti-freezing function.
4. Filter should be installed before water inlet and cleaned regularly, cleaning cycle is recommended to be 3 months/time.

## SWIMMING POOL HEAT PUMP

5. The heat exchanger shall be regularly cleaned with cleaning fluid to avoid heat pump failure caused by scaling. Recommended cleaning cycle 3 months/time. When the water quality is hard or high temperature water is used for a long time, the cleaning cycle should be shortened appropriately.

### **Warning: electric shock**

Before the operation of the heat pump, please confirm the grounding wire is connected or not. Check whether the wiring power is consistent with the power required by the label.

### **Warning: rotation attention**

Please do not put your hands or any objects into the fan blade, which is likely to cause fan blade damage and personal injury.

### **Be careful with electricity**

This equipment can only be operated and maintained by professionals.

For your safety - This product must be installed by a licensed HVAC technician certified in heat pump repair and maintenance by the jurisdiction in which the product will be installed where such state or local requirements exists. The technician must possess and comply with all certifications and regulations regarding the purchasing, handling, transportation and reclamation of refrigerant. In the event no such state or local requirement exists, the installer or maintainer must be a professional with sufficient experience in pool equipment installation and maintenance so that all of the instructions in this manual can be followed exactly. Before installing this product, read and follow all warning notices and instructions that accompany this product. Failure to follow warning notices and instructions may result in property damage, personal injury, or death. Improper installation and operation can create an electrical hazard which can cause serious injury, property damage, or death. Improper installation and/or operation will void the warranty.

### **Attention**

Installation and service must be performed by a qualified installer or service agency. To the installer: After installation, these instructions must be given to the homeowner or left on or near the heat pump. This manual contains important information that will help you in operating and maintaining this heat pump. Please retain it for future reference.

### **! WARNING**

The elevated water temperature can be hazardous. Consult heater operation and installation instructions for water temperature guidelines before setting temperature.

### **! WARNING**

The following "Safety Rules for Hot Tubs," should be observed when using the spa.

## SWIMMING POOL HEAT PUMP

### ! WARNING

Spa or hot tub water temperature should never exceed 104°F (40°C). One hundred degrees Fahrenheit (100°F [38°C]) is considered safe for a healthy adult. Special caution is recommended for young children.

### ! WARNING

The drinking of alcoholic beverages before or during spa or hot tub use can cause drowsiness which could lead to unconsciousness, and subsequently result in drowning.

### ! WARNING

Pregnant women take note! Soaking in water above 102°F (38.5°C) can cause fetal damage during the first three (3) months of pregnancy (which could result in the birth of a brain-damaged or deformed child). If pregnant women are going to use a spa or hot tub, they should make sure the water temperature is below 100°F (38°C) maximum.

### Attention

The water temperature should always be checked with an accurate thermometer before entering a spa or hot tub. Temperature controls may vary by as much as 35.6F° (2°C).

### ! WARNING

Persons with a medical history of heart disease, diabetes, circulatory or blood pressure problems should consult their physician before using a hot tub or spa.

### ! WARNING

Persons taking any medication which induces drowsiness (e.g., tranquilizers, antihistamines, or anticoagulants) should not use spas or hot tubs.

### ! WARNING

Hyperthermia occurs when the internal body temperature reaches a level several degrees above the normal body temperature of 98.6°F (37°C). Symptoms include dizziness, fainting, drowsiness, lethargy, and an increase in the internal body temperature. The effects of hyperthermia include:

- . Lack of awareness of impending hazard
- . Failure to perceive heat
- . Failure to recognize need to leave spa
- . Physical inability to leave spa
- . Fetal damage in pregnant women
- . Unconsciousness resulting in a danger of drowning

### ! CAUTION

When pool equipment is located below the pool surface, a leak from any component can cause large scale water loss or flooding. Supplier cannot be responsible for such water loss or flooding or resulting damage.

### ! CAUTION

Make sure that flow requirements and pool water turn over rates can be maintained with the installation of additional heat pumps and plumbing restrictions.

## SWIMMING POOL HEAT PUMP

### ! WARNING

A check valve can interfere with the proper operation of certain Suction Vacuum Release System (SVRS) products. To avoid possible entrapment hazard, serious injury, or death, make sure to review the operation/owners manual of your particular SVRS product before installing the check valve. (quilizers, antihistamines, or anticoagulants) should not use spas or hot tubs.

### ELECTRICAL SHOCK HAZARD

This heat pump contains wiring that carries high voltage. Contact with these wires may result in severe injury or death. Disconnect power circuit before connecting the heat pump

### ! CAUTION

Label all wires prior to disconnection when servicing controls. Wiring errors can cause improper and dangerous operation. Verify proper operation after servicing.

### ! CAUTION

This heater must be connected to a bonding grid with a solid copper wire not smaller in diameter than 8 AWG (In Canada, it shall be no smaller than 6 AWG.)

### ! CAUTION

Do not use this heat pump if any part has been under water. Immediately call a qualified service technician to inspect the heater and replace any part of the control system which has been under water.

### ! CAUTION

Keep all objects off the top of the heat pump. Blocking air flow could damage the unit and may void the warranty.

### ! CAUTION

The water pressure switch should be adjusted to turn the heater off when the pump is off. Setting the switch to close at too low of a flow can damage the appliance. Adjust the switch to turn the heater off, not on.

### ! CAUTION

Failure to winterize could cause damage to the heat pump and will void the warranty.

# SWIMMING POOL HEAT PUMP

## I. Parameter

Model	130KW HEAT PUMP DC
Power Supply	380V/3Ph/50Hz
Operating Air Temperature(°C)	-15~43
<b>Heating Capacity: Air 27°C/Water 26°C/Humidity 80%</b>	
Boost Mode Capacity (kW)	<b>130</b>
Heating Capacity(kW)	21~130
Consumed Power(kW)	1.3~21.00
COP	6.15~16.11
<b>Heating Capacity: Air 15°C/Water 26°C/Humidity 70%</b>	
Boost Mode Capacity (kW)	<b>96</b>
Heating Capacity(kW)	16.05~96
Consumed Power(kW)	3.24~19.2
COP	4.95~8.45
<b>Cooling Capacity: Air 43°C/Water 26°C/Humidity 70%</b>	
Boost Mode Capacity (kW)	<b>67.2</b>
Cooling Capacity(kW)	25.5~67.2
Consumed Power(kW)	4.93~15.36
EER	4.15~5.13
Compressor	DC inveter type
Compressor quantity	2
Fan	DC fan motor
Fan quantity	1
Sound Pressure 1m dB(A)	65
Water Flow Volume (m3/h)	41.25
Refrigerant Gas	R410A
Fan Direction	vertical
Fin	Gold
Crank case heater	Yes
condensate tray heater	70W/m
Wifi function	Yes
Water Pressure Drop	45

# SWIMMING POOL HEAT PUMP

## II. Dimensions

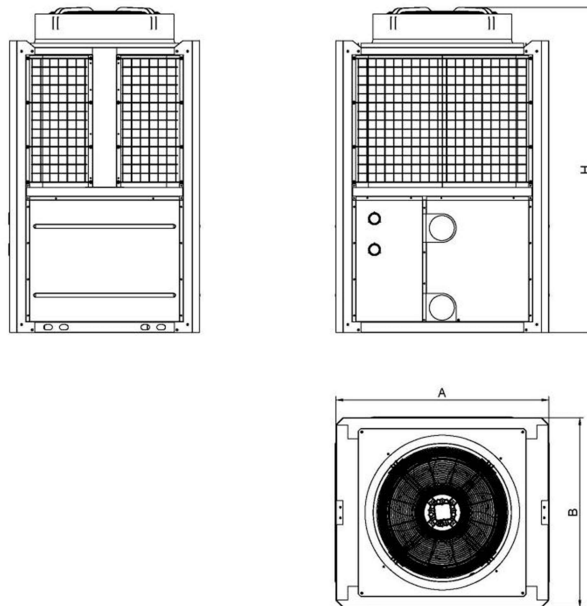

Units: mm

Model	130KW HEAT PUMP DC
Size	
A	1203
B	1073
H	1910

## III. Installation

### 1. Unit installation position

To avoid ventilation short, the unit's discharged air should not be return when installation. Please keep enough space around the unit for repair. Right and wrong means as below:

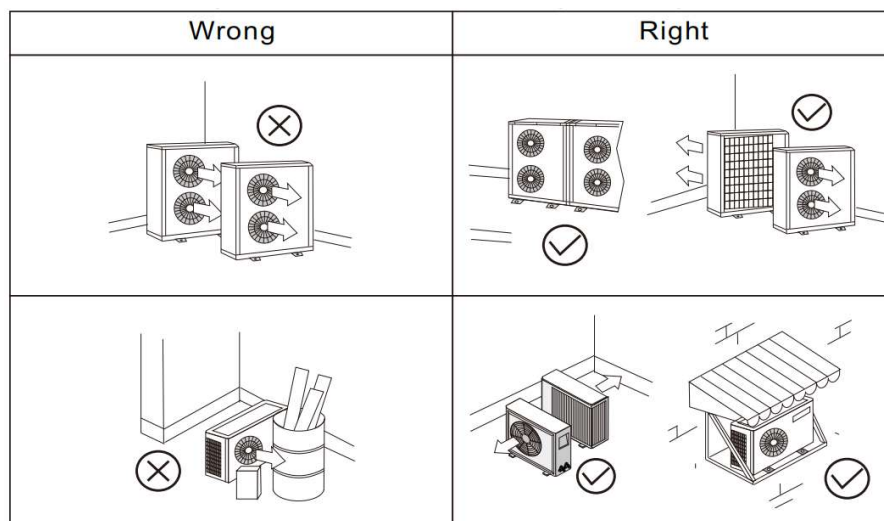

# SWIMMING POOL HEAT PUMP



1. To get enough air for ventilation of the unit, the installation position should be with good ventilation.

Notice:

2. The installation position can hold the outdoor unit without noise and shake.
3. No sunlight to the unit. Set an awning if necessary.
4. The water from rain and defrosting can be discharged in the installation position.
5. The unit will not be covered by snow in the installation position.
6. The discharged air will not face strong air in the installation position.
7. Assure the noise caused by the unit ventilation and operation will not affect the neighbour.
8. The installation position will not be affected by garbage, oil and mist.
9. The unit will be damaged under the condition with oil(engine oil), salt(sea area) and sulfide air(near thermal spring and refining factory).

## 2. Heat Pump Positioning

2.1 For correct operation air must be free to circulate around the heat pump. Do not place the unit in a shed, greenhouse or similar. This unit is designed to be placed outdoors only.

2.2 Refer to the drawing below for required clearance.

2.3 You should position the heat pump so that the control panel does not face directly towards the sun.

2.4 The heat pump must be upright.

2.5 The distance between the heat pump and the pool / plant room should be as short as practically possible to reduce pressure and heat loss in the pipe work.

2.6 Insulating the pipe work will assist with the prevention of heat losses.

2.7 An isolator switch should be installed (by a qualified electrician) near the heat pump.

2.8 The electrical supply to the heat pump must be protected by a 30mA RCD.

2.9 The air inlets and outlets must not be obstructed or blocked.

2.10 Even though the heat pump is low noise, it must be positioned so as to be considerate to neighbours.

2.11 Your heat pump must be placed on a solid base.

2.12 Condensation will drip from underneath the heat pump, your base must be able to tolerate this.

### The position of installing unit

A. Side fan type installation space requirements:

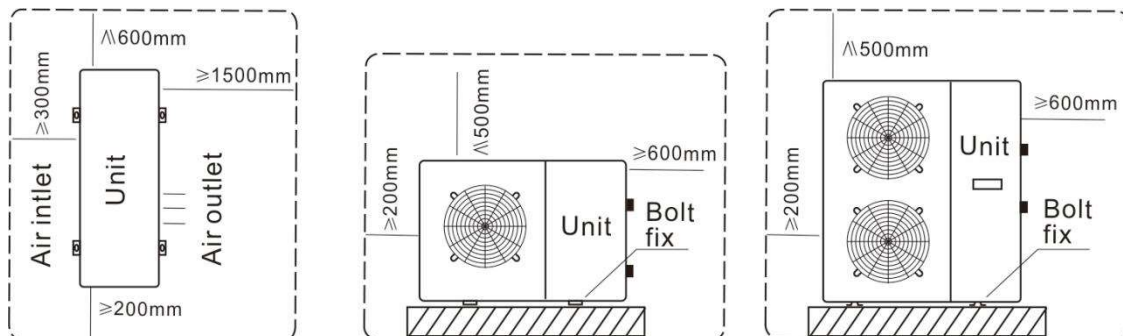

# SWIMMING POOL HEAT PUMP

## 3. Pool Pipe Connecting

- 3.1 The pool water is fed through the heat pump by a swimming pool pump.
- 3.2 The heat pump must be installed after (down stream) the swimming pool filter so clean, filtered water passes through it.
- 3.3 Double union ball valves must be fitted just before the heat pump inlet and just after the outlet to aid servicing and winterising.
- 3.4 Each heat pump has a maximum water flow rate. If the flow via the pool pump is higher than this then a by-pass should be installed. Consult your supplying dealer.
- 3.5 Each heat pump also has a minimum flow rate, below this the heat pump will not operate. Consult your supplying dealer.
- 3.6 Pipe work of less than 1-1/2 inch diameter should not be used.
- 3.7 Fit a union joint onto each pipe.
- 3.8 Push the gasket over the pipe until the gasket is about 5 -10mm from the edge of the pipe. You may need to lubricate the gasket.
- 3.9 Insert the pipe into the heat pump and tighten the union joint.
- 3.10 The union must only be hand tightened.
- 3.11 If the swimming pool is equipped with a chlorinator, brominator, or possibly chemical control with acid and chlorine pumps, there must be a non-return valve used in the return pipe work after the heat pump. Any dosing system must be the final equipment before the water returns to the swimming pool. Damage to the heat pump caused by chemical dosing
- 3.12 Any heat exchanger or electric heater fitted as auxiliary heating must be installed after (down stream from) the heat pump so as to avoid pre-heating the pool water before it enters the heat pump.

### Installation Drawing

1:Picture 1 effective for the side fan type models.

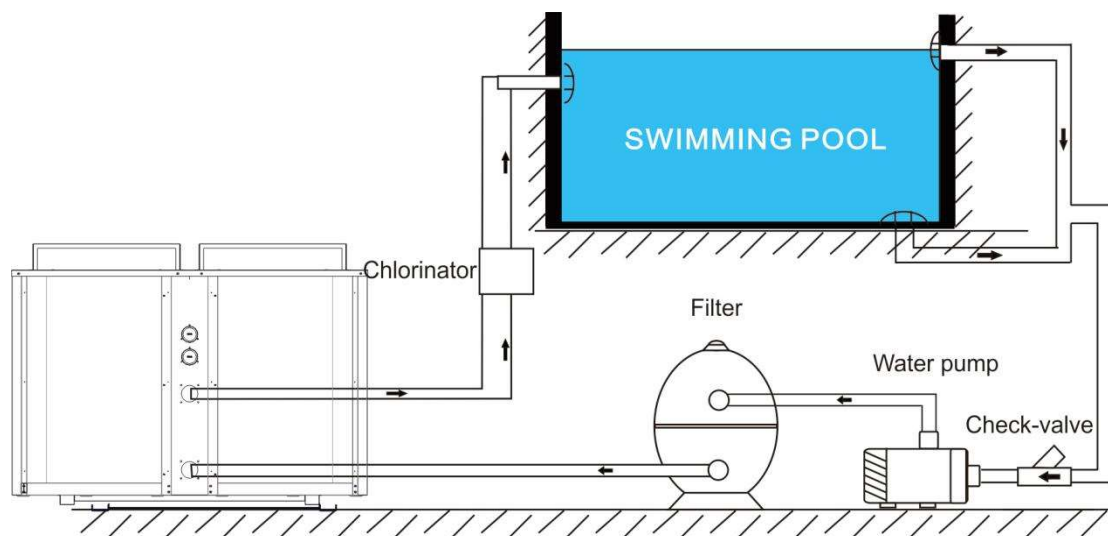

# SWIMMING POOL HEAT PUMP

## 4. Electric wiring

4.1 Unit supply cable must be used copper. Power supply voltage should be in line with the rated voltage and the rated current.

4.2 The unit, power supply circuit must have a grounding wire, and the power supply ground wire must connect to the external grounding wire, and an external grounding wire to be effective.

4.3 Wiring installation must be installed by professional technicians carried out in accordance with circuit.

4.4 Setting up a good leakage protection devices and in accordance with the relevant national technical standards.

4.5 Power line and signal line layout should be neat, rational, strong and weak lines separating cable and Can not interfere with each other, without contact with the connecting pipe and valve.

4.6 After the construction of all wiring is completed, carefully check the correct order to connect the power.

4.7 Unit electric wire connection: connect to the appropriate terminals according to wiring diagram, and fix it by the pressure line of board in the electrical box.

4.8 All the wiring construction is completed, can be plugged in only after careful examination correctly.

4.9 Unit control board fuse parameters: 5A.







# SWIMMING POOL HEAT PUMP

## IV.USE

### 1. Display interface



### 2. Key function definition

Key icon	meaning	Name
	Represents the on-off key, used to turn the machine on and off.	on-off
	Query key, used to query group status. Note: The return key is used in the sub-interface.	Query return
	Indicates the upward icon, which allows you to turn pages upward and add parameters	upward
	Indicates the downward icon, which allows you to scroll down and reduce parameters	downward
	Indicates the setting icon. The parameter setting directory page is displayed. Note: Confirm, enter or set the key in the sub-interface.	Setting Confirm Enter
	Represents the mode key icon, used to set the machine running mode.	Model Check

## SWIMMING POOL HEAT PUMP

	Note: As a check key in the sub-interface.	
--	--	--

# SWIMMING POOL HEAT PUMP

## 3. Main interface



No.	Meaning	Name
1	Indicates the system time (hour: minute).	system time
2	Indicates the strength of the WIFI signal. Display only when the device has this function.	WIFI signal
3	When heat pump have error, this icon will appear and flash	Error icon
4	Represents the system date.	system date
5	Indicates the set temperature of the device in the current operating mode.	set temperature
6	Indicates the current operating water temperature of the device.	water temperature
7	Indicates the current running mode of the device.	running mode
8	Indicates the current status of the device.	current status

In this interface, you can adjust the setting temperature by pressing the "up" or "down" button

# SWIMMING POOL HEAT PUMP

## 4. Mode selection

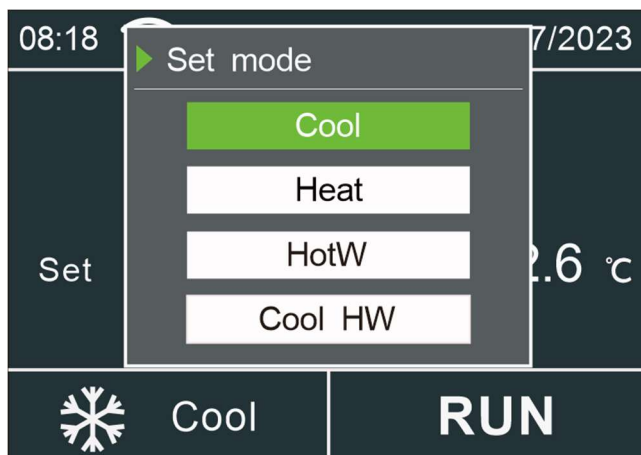
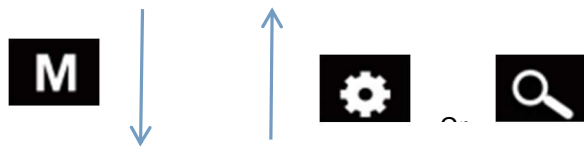
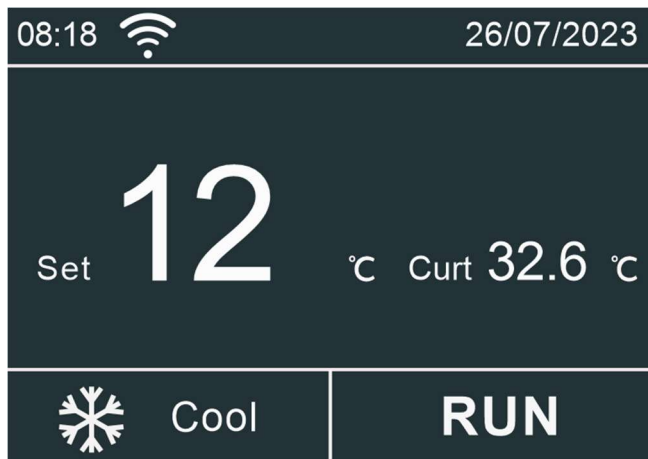

1. On the main interface, press the "Model" button to enter the model selection interface.

1. On this interface, press the "Up" or "Down" button to select the Cool /heat/HotW/Cool HW/Heat HW modes.
2. After confirming the model, press the "Confirm" or "Return" button to return to the main interface.

# SWIMMING POOL HEAT PUMP

## 5. Parameter setting

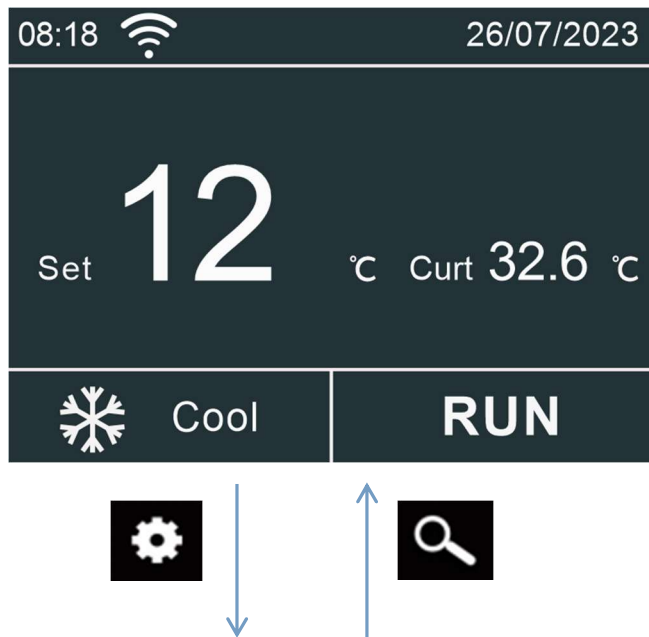

1、 On the main interface, press [Settings] to enter the parameter setting directory screen

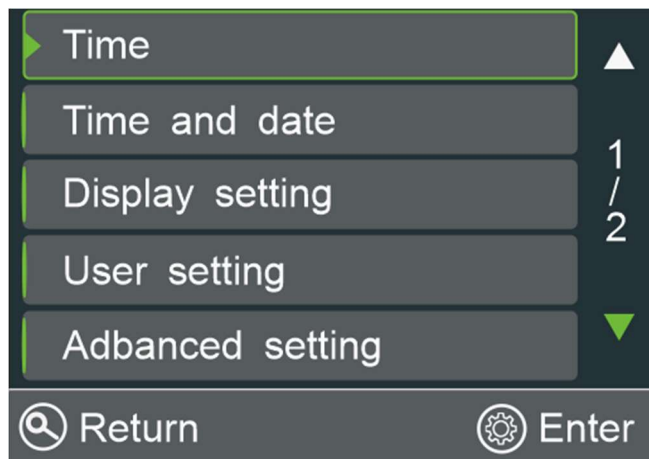

1、 On the interface, press the "Up" or "Down" button to select the parameters to be set;

2、 Press the "Enter" button to enter the corresponding setting parameters;

3、 Press [Back] to return to the main interface;

4、 Timing Settings: You can set the timing of the device on or off on this screen.

2、 Time and date: Set the date and time of the system on this screen.

3、 Display Settings: You can modify the display parameters of the wire controller on this screen.

4、 User Setting: allows you to set various device parameters on this screen. A user password is required to access the screen.

5、 Advanced Setting: This option is the option of the device manufacturer.

6、 WIFI Setting: This is a WIFI connection option.

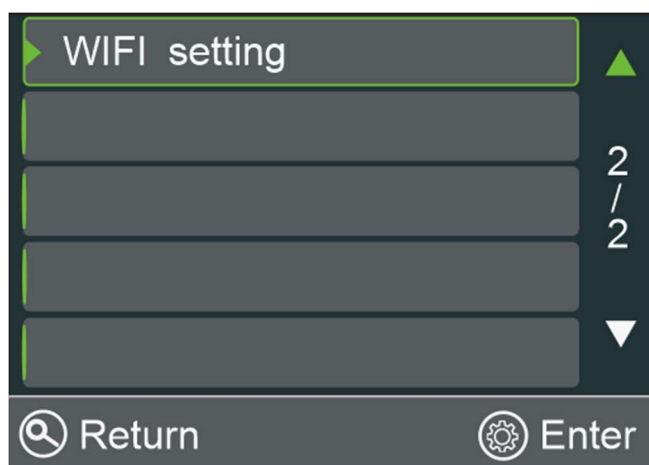

# SWIMMING POOL HEAT PUMP

## 5.1 Timing switch setting

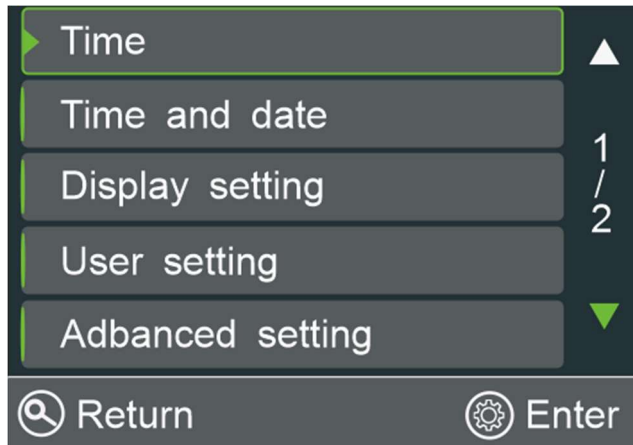

1、 On the Parameter Setting directory screen, press the [Up] or [Down] button, select Timing Settings, and press the [Enter] button to enter the Timing Settings screen.

2、 To enter the interface of timing setting, press the "Up" or "Down" button to select the "Time", "Command" and "Week" to be timed (for the selected parameter, the background color will turn green, press "Setting", and then press the "up" or "down" button to

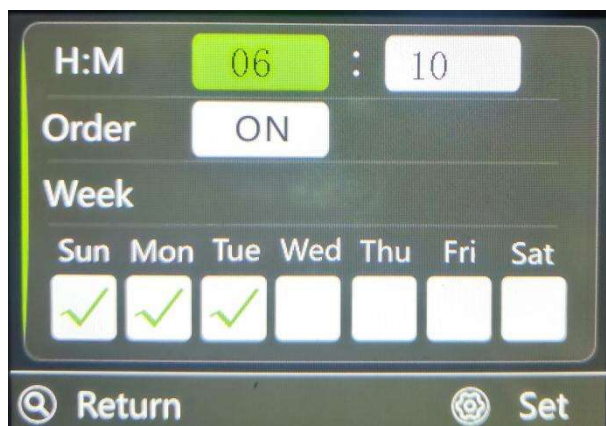
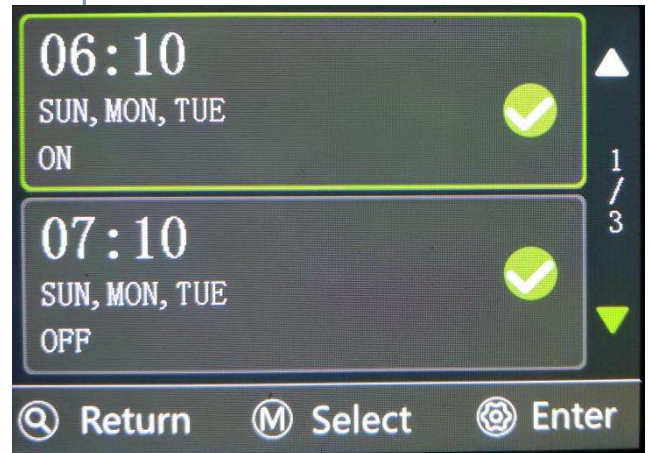
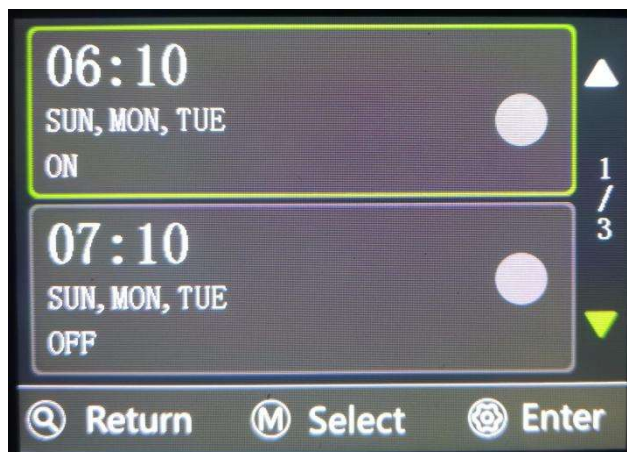

3、 After setting the timing parameters, remember to press the "Select" button to select the required timing Settings (if not checked, this function will be invalid).

4、 Three time periods can be set for timed power on/off, and the settings for each period are the same as above.

# SWIMMING POOL HEAT PUMP

## 5.2 Date and time Settings

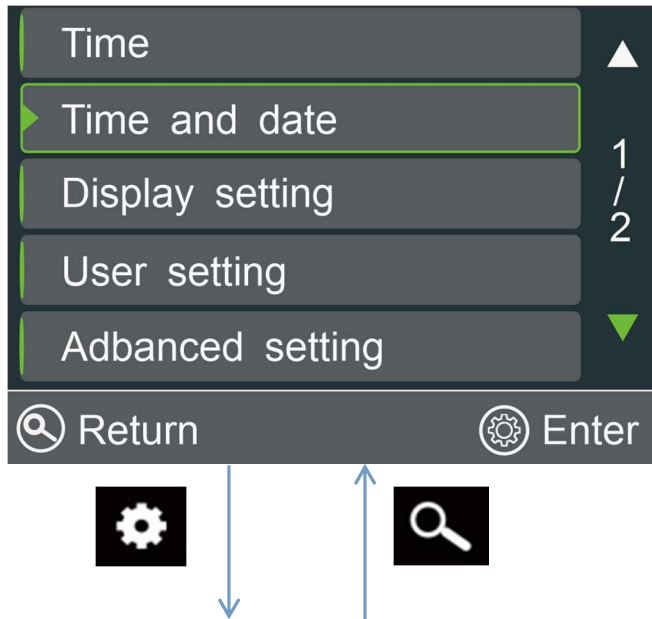

1、 On the Parameter setting directory screen, press the [Up] or [Down] button, select Date and Time, and press the [Enter] button to enter the "Time and date" screen.

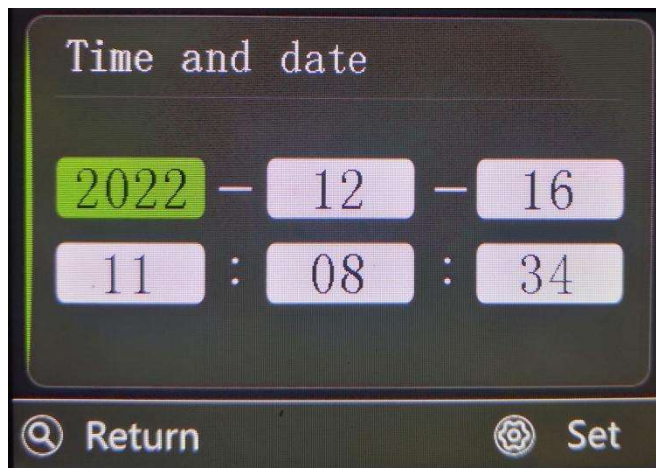

1、 Enter the "Time and date" interface, press the "Up" or "Down" button, and select the "Year", "month", "day", "hour", "minute" and "second" to be set (for the selected parameter, the background color will turn green, press "Setting", and then press the "up" or "down" button to adjust the value).

# SWIMMING POOL HEAT PUMP

## 5.3 display setup

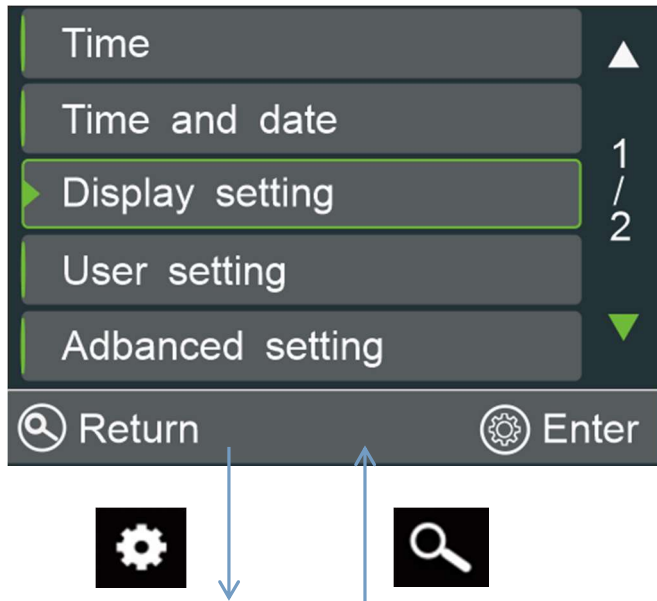

1、 On the parameter setting directory interface, press the [Up] or [Down] button, select "Display Settings", and press the "Enter" button to enter the "Display Settings" setting interface.

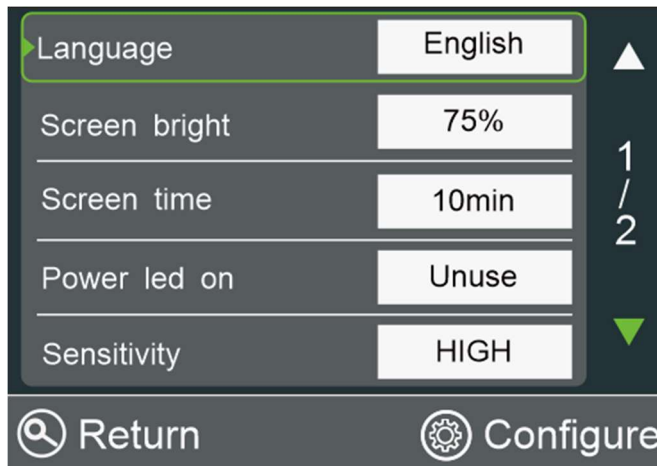

1、 "Language" : The control panel can be switched to Chinese or English;

3、 "Screen Time" : You can set the time when the screen will go out after no operation;

4、 "Power lamp on" : set the power indicator light on and off of the wire controller;

5、 "Sensitivity" : the sensitivity of the key can be adjusted, with four options: high, medium, low and disabled (the default value is recommended);

6、 "Temp.cmpst" : this function is invalid;

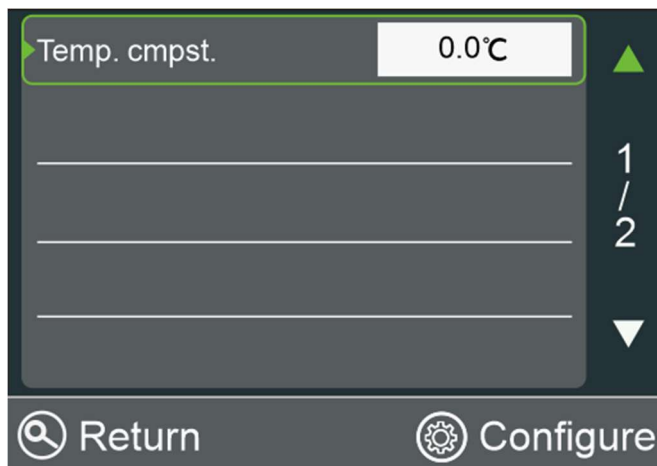

# SWIMMING POOL HEAT PUMP

# SWIMMING POOL HEAT PUMP

## 5.4 User set directory

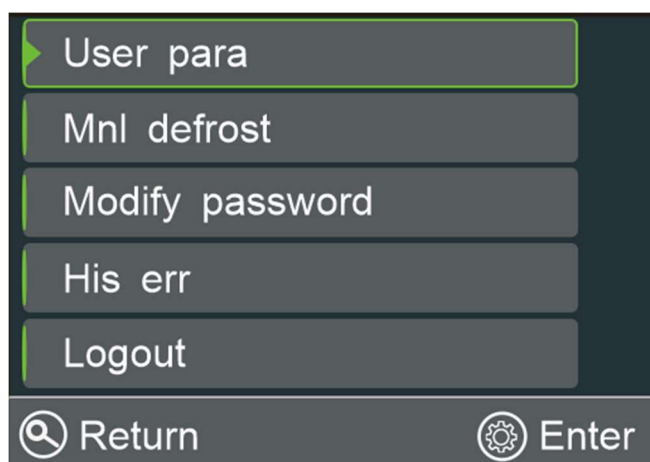
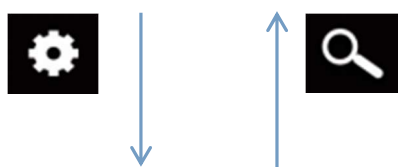
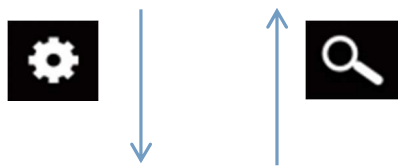
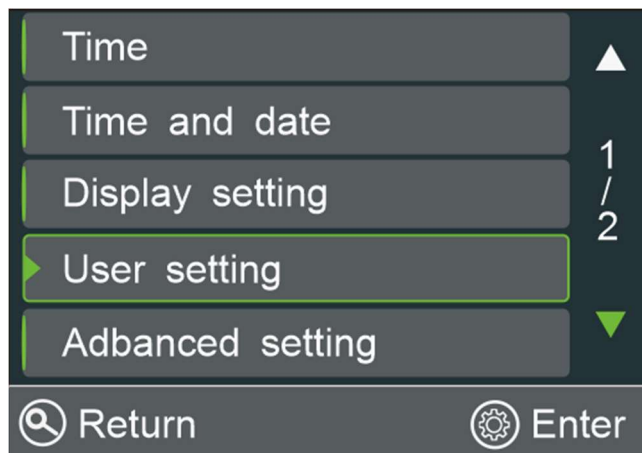

1、 On the Parameter Setting directory screen, press the [Up] or [Down] key, select User Settings, and press the [Enter] key to enter the User Settings screen.

1、 Enter the " Input password " interface, enter the user password: 123, (press the selected digit "shift", the background color will turn green, then press the "up" or "down" button, respectively from left to right to enter 123 three digit password value).

2、 After entering the password, press the "Confirm" button. If the password is correct, the User Para directory page is displayed. If the password is incorrect, the user cannot enter the directory, should need to reenter the correct password.

1、 User Parameters: You can set device parameters on this screen.

2、 "Manual Defrost" : You can manually defrost by entering this interface;

3、 "Modify Password": Allows to change the original password on this screen.

4、 "His err": You can view historical faults of the device on this screen.

5、 "Log Out": You can log out of the user on this screen and restore the function that requires you to enter the password to enter the user Settings.

# SWIMMING POOL HEAT PUMP

## 5.4.1 User parameter setting

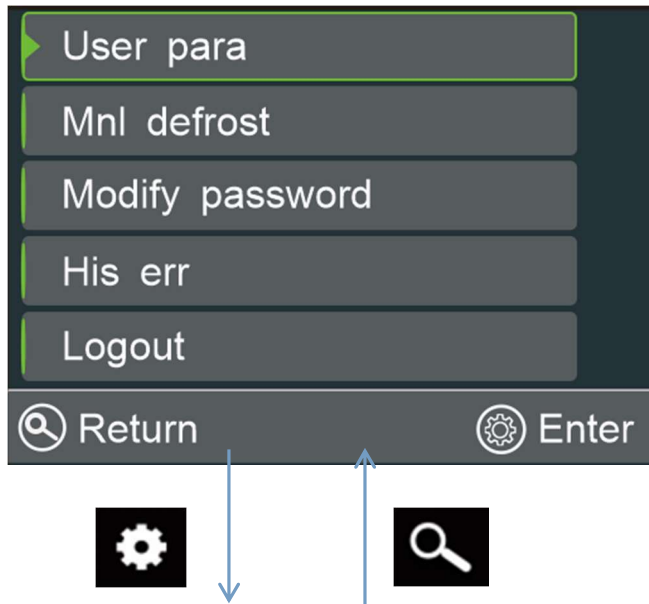

1、 On the User Para directory screen, press the [Up] or [Down] key, select User Parameters, and press the [Enter] key to enter the User Settings screen.

Parameter adjustment operation: press the "Up" or "Down" button to select the parameter to be modified, and then press the "Set" button, or press the "Set" button to adjust the parameter through the "Up" or "down" button.

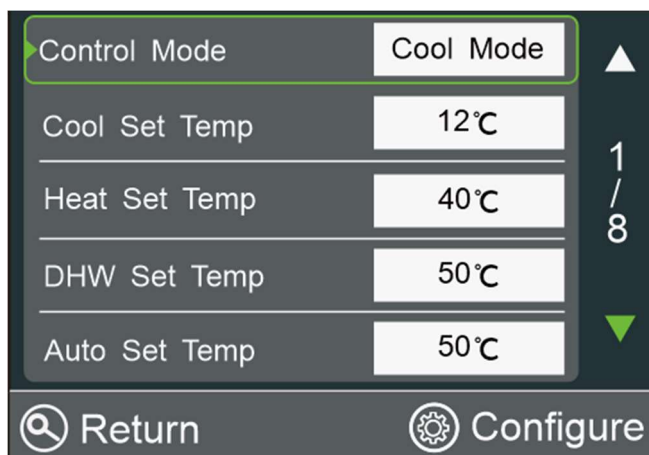

1、 Press the [Up] or [Down] key, View and set other parameters,For details,please refer to "Attcahed Table 1".

# SWIMMING POOL HEAT PUMP

## 5.4.2 Manual defrosting

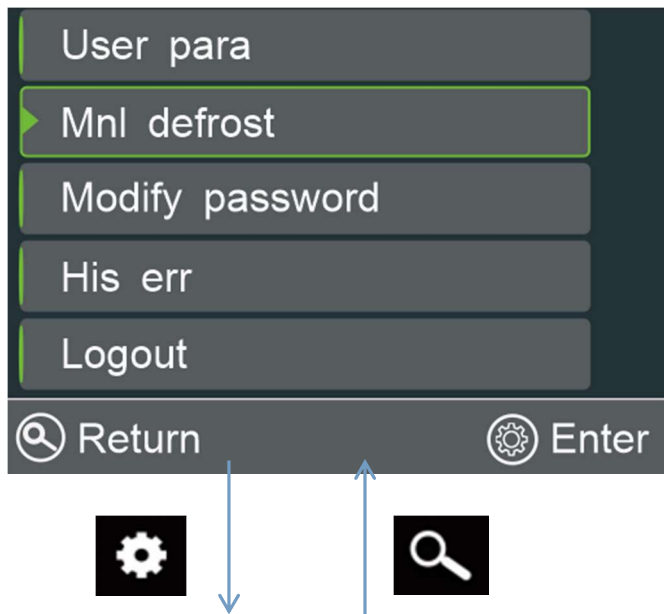

1、 On the User Parameter directory screen, press the [Up] or [Down] button to select “Mnl Defrost”. Press the [Enter] button to enter the setting screen of “Mnl Defrost”.

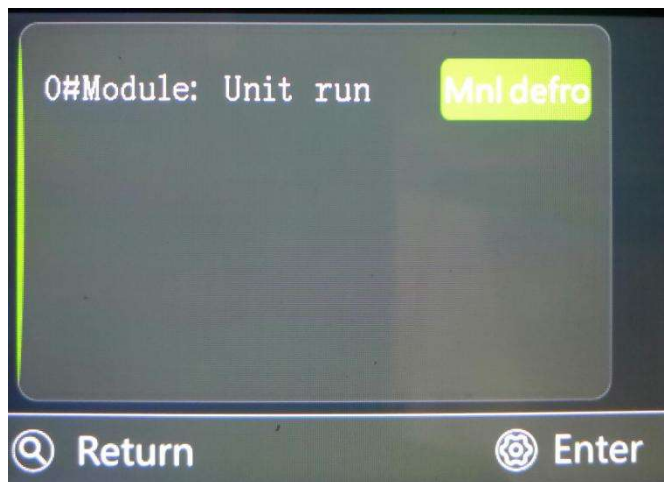

1. Press the "Enter" button on the interface, and the device can enter the manual dehumidification state. After defrosting, the device will automatically restore to the original state.

# SWIMMING POOL HEAT PUMP

## 5.4.3 User password change

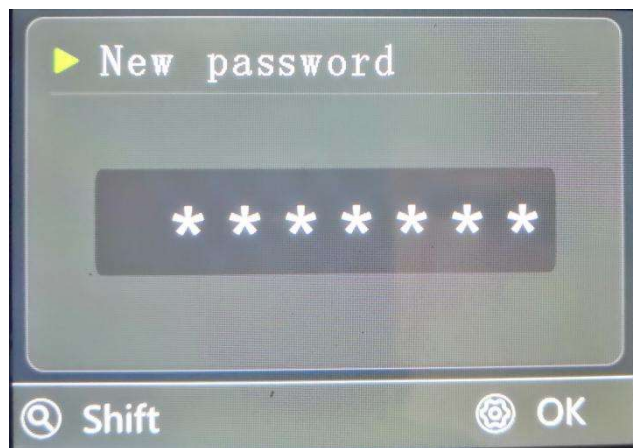
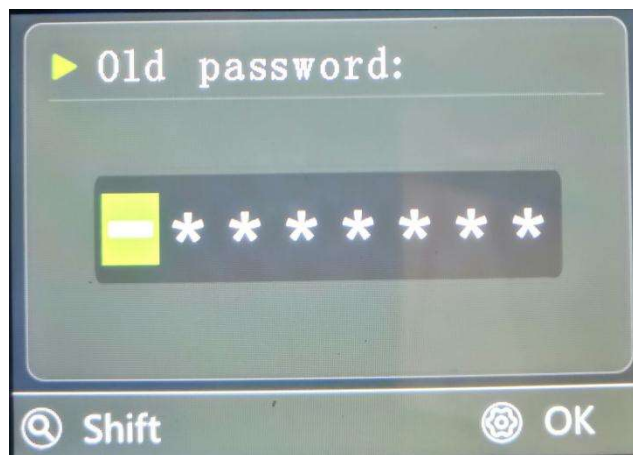

1. On the User Parameter directory screen, press the [Up] or [Down] key, select "Modify Password", and press the [Enter] key to enter the Password setting screen.
2. Enter the correct old password to enter the new password interface;
3. If you need to exit from the old password input interface, please press the "Enter" button directly or press the "Enter" button if you enter the wrong password, the password error dialog box will pop up at this time;
4. After re-entering the new password, press the "OK" button, prompting you to enter the new password again, and then press the "OK" button, the password is successfully changed and returned to the user parameter directory interface (please remember the new password after changing the password).

# SWIMMING POOL HEAT PUMP

## 5.4.4 Historical fault query

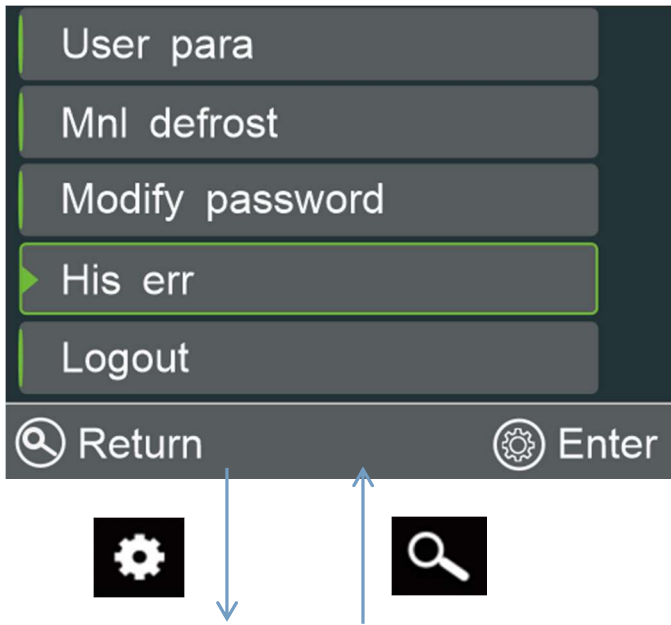

1、 On the User Parameter Directory screen, press the [Up] or [Down] key, select "His err", and press the [Enter] key to go to the Historical Fault Query screen.

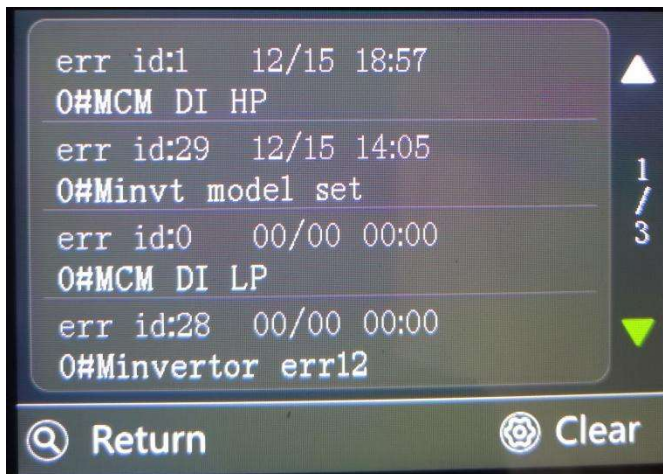

1、 On this screen, view the fault type and fault occurrence time of the device.

2、 In this interface, press the "Clear" button to clear all fault records (once the fault records are cleared and cannot be recovered, please exercise caution);

## 5.4.5 Account cancellation

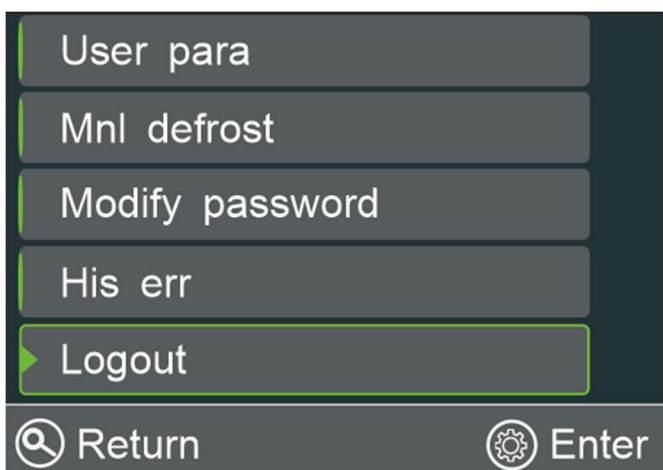

1、 Press the "Up" or "Down" button, select "His err ", and press the "Enter" button to log out of the user. When you enter the "User Settings" screen again, you need to enter the password again.

1、 If you do not logout and the online controller does not enter the screensaver, there is no need to re-enter the password when you re-enter the User Settings screen.

3、 After you logout, the Parameter Settings directory page is displayed.

# SWIMMING POOL HEAT PUMP

## 5.5 WIFI setting

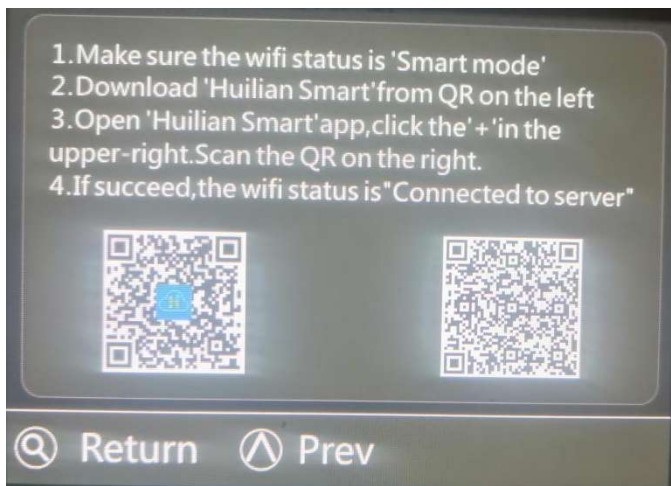
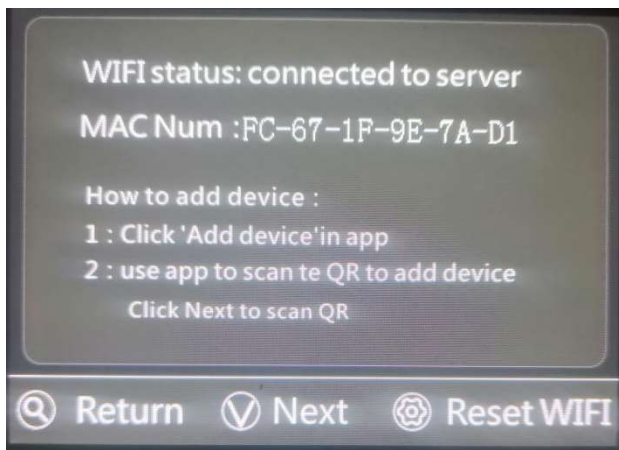
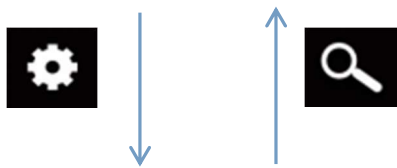
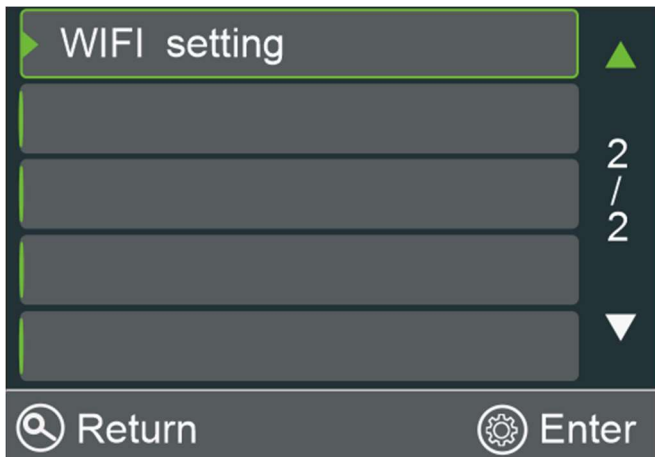

1、 On the parameter setting directory screen, press the "Up" or "Down" button, select "WIFI Setting", and press the "Enter" button to enter the "WIFI Setting" screen.

1、 Follow the instructions step by step to connect to WIFI and control the device through the APP.

### 2、 Android System

Download the "Huilian Smat" APP from QR.



### 3、 IOS System

Searches and installs the "Huilian Smart" app on the APP Store and registers it

# SWIMMING POOL HEAT PUMP

## 5.6 Device information query

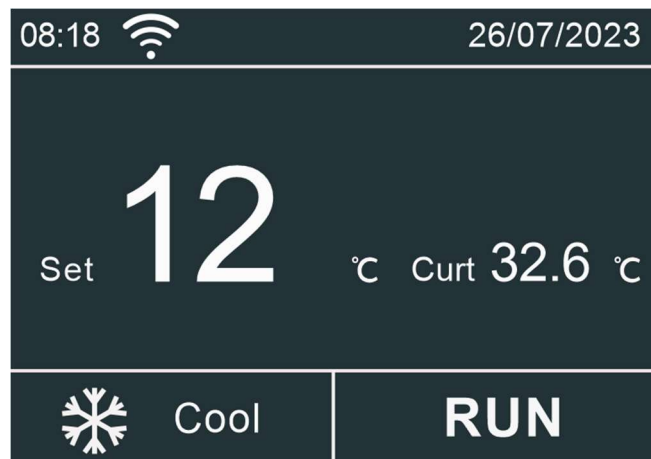

1、 On the home screen, press Query to enter the Query Device Status screen.

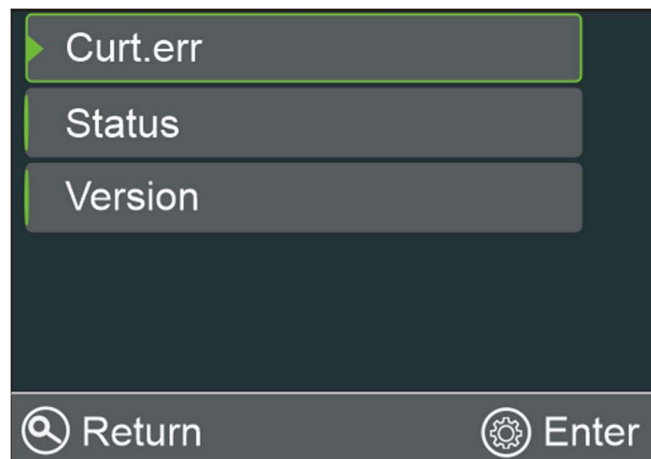

- 1、 "Curt.err": Query the current fault of the device.
- 2、 "Status": Queries the current running status parameters of the device.
- 3、 "Version" : query the driver version number of the device;

# SWIMMING POOL HEAT PUMP

## 5.6.1 Current fault query

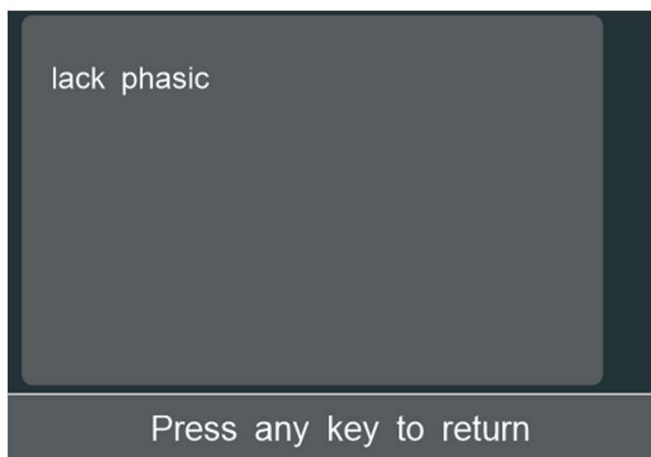
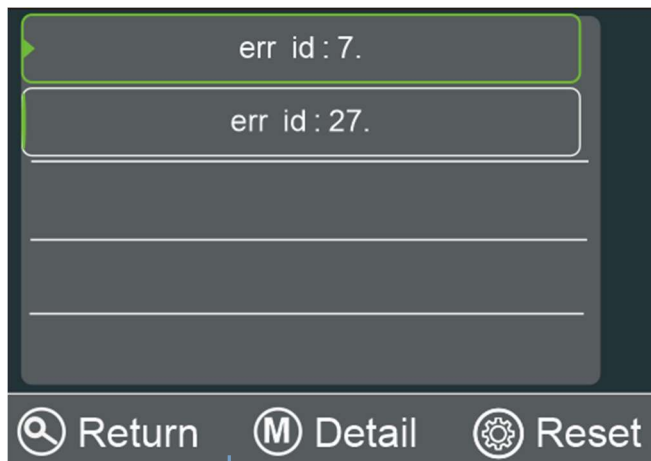
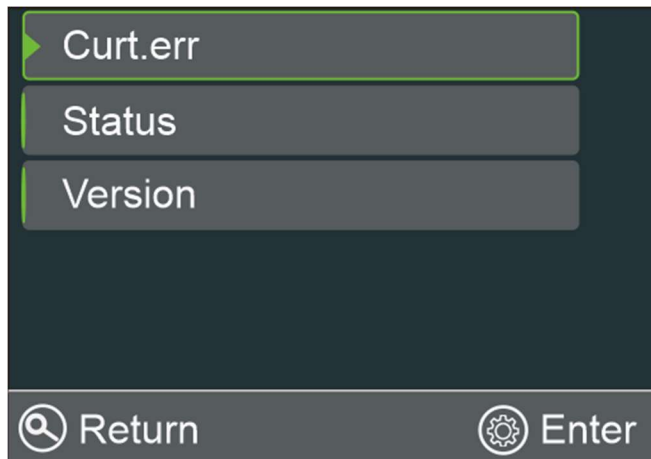

1、 On the device status query screen, press the [Up] or [Down] key and select“Curt.err”. The Current Fault screen is displayed

- 1、 Press the “Detail” button to viewing err information;
- 2、 After the fault is removed, press the “Reset” button to eliminate the current fault;

# SWIMMING POOL HEAT PUMP

## 5.6.2 Status query

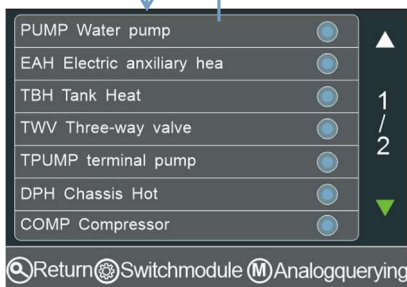
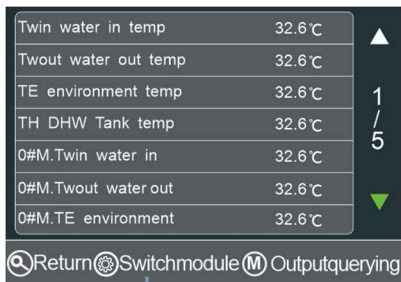
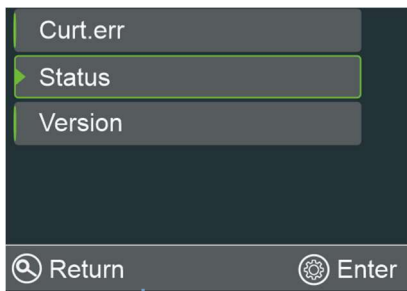

1、 On the device status query screen, press the [Up] or [Down] key and select "Status Query". The "Status Query" screen is displayed

- 1、 Press the "Up" or "Down" button to turn the page and view other status parameters;
- 2、 Press the "Outputquerying" button to check the output status of the device;
- 3、 "Switch module" button, which only works when a wire controller controls multiple units;

- 1、 Press the "Up" or "Down" button to turn the page and view other output status of the device;
- 2、 Press the "Analogquerying" button to check the status parameters;
- 3、 "Switch module" button, which only works when a wire controller controls multiple units;

## 5.6.3 Version query

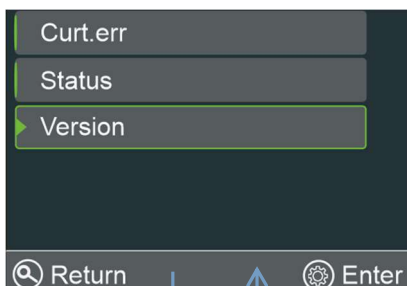

1、 On the device status query screen, press the [Up] or [Down] key and select "Version". The "Version" screen is displayed

## SWIMMING POOL HEAT PUMP

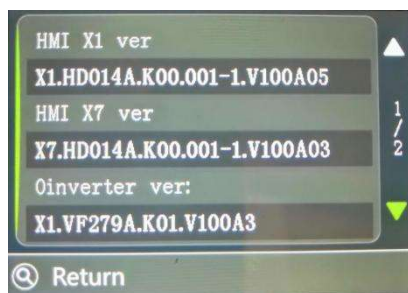

1、 Press the "Up" or "Down" button to turn the page and view other version information;

# SWIMMING POOL HEAT PUMP

## V.Maintenance

### 1.Note

1.1 Check whether the exhaust equipment is normal. Avoid cutting of the water supply and or air entering into the system, or it will influence the performance and reliability of the unit. The water filter should be cleaned regularly. Keep the water clean in case of any damage to the unit due to filter's dirty and jam.

1.2 Keep the unit environment dry, clean and well ventilation. Clean the side air exchanger regularly(once per 1-2 months) in order to maintain high exchange efficiency and save energy.

1.3 Usually check the performance of all the parts in the unit. Check whether the working pressure of the refrigerant system is normal. Repair and change the parts timely if there's any abnormality.

1.4 Usually check whether the wiring of the power and electric system is tightened and or electric parts perform abnormally or smells. Repair and change the parts timely if there's any abnormality.

1.5 Care the unit if the unit stops for a long time. Discharge all the water in the pump and throughout the pipe route in case breakdown to the water pump and pipe caused by frost and freeze. Discharge the water from the water pump and tube exchange Button drain. Check the unit thoroughly and flood water into the system before the unit power on again

1.6 To check the operation of every process in the unit, the operation pressure of the refrigerant system. You should maintain or change it in time.

1.7 To check the power supply and cable connection usually, there is abnormal action or bad smell about the electrical component. If there is, please maintain or change it in time.

## 2.Debugging And Running

### 1.Preparation Before Debugging

1.1 Checking-up of the Air Source Heat Pump unit.

A. Check to assure that the appearance of the unit and the inner pipe system are not damaged in the transportation process.

B. Check if there is air in the water pipes of the unit. If yes, please remove all the air through the vent valve on the water tubes and vent valves on the water pump.

C. Check to assure that the blades of the fan do not touch the fixed panel or the protection net of the fan.

1.2 Checking the electric supply system.

A. Check if the power supply source accords with the power source required in this manual and the nameplate on the unit.

B. Check if all the electric power supply and control lines are connected properly and confirm that the lines are connected according to the diagram and the grounding is

## SWIMMING POOL HEAT PUMP

reliable and the heads of all the lines are firm enough.

### 1.3 Check the pipeline system

A. Confirm that the system pipe, manometer, valves, and other instruments are correctly installed.

B. Confirm that the valves in the system are open or closed properly.

C. Check if the insulation system is in a good condition.

## 2. Commissioning

2.1 The test running of the unit must be operated by a professional engineer !

2.2 After taking full examination of the whole system, if all parts are confirmed to be according to installation requirements, test running of the entire unit can be done.

2.3 The unit will turn on automatically 1 minutes later after connecting to the electric source and turning on the Heat Pump.

2.4 Check if the unit is running in accord with the requirements. Users can use the Air Source Heat Pump after testing properly for at least 8 hours.

## 3.Determine and solve malfunction by below table:

Malfunction	Reason	Solution
The unit can't run	<ol style="list-style-type: none"> <li>1.Power failures</li> <li>2. The unit wire loses</li> <li>3. The unit power fuse burns out.</li> </ol>	<ol style="list-style-type: none"> <li>1. Shut down and check the power</li> <li>2.Check the reason and repair</li> <li>3.Check and change the power fuse</li> </ol>
The water pump can run but can't circulate and is noisy	<ol style="list-style-type: none"> <li>1. The water system is lack of water</li> <li>2. There's air in the system.</li> <li>3. The water system valve doesn't open entirely</li> <li>4. The water filter is dirty and jam</li> </ol>	<ol style="list-style-type: none"> <li>1.Check the water supplement equipment and supply water into the system.</li> <li>2.Exhaust the air from the water system</li> <li>3.Clean the water filter or exhaust the air from system</li> <li>4.Clean the water filter</li> </ol>
The cooling capacity is too low and the compressor works continuously without pause.	<ol style="list-style-type: none"> <li>1. Refrigerant is insufficient</li> <li>2. Thermal insulation of the water system is poor</li> <li>3. Thermal discharge of the exchange is poor</li> <li>4. Water flow volume is insufficient</li> </ol>	<ol style="list-style-type: none"> <li>1.Check the leakage and add refrigerant</li> <li>2.Enhance the thermal insulation of the pipe route</li> <li>3.Clean the exchanger and improve the condensation condition</li> <li>4. Clean the water filter</li> </ol>
The compressor exhausted pressure is too high	<ol style="list-style-type: none"> <li>1.Too much refrigerant</li> <li>2.Thermal discharge of the exchange is poor</li> </ol>	<ol style="list-style-type: none"> <li>1. Discharge surplus refrigerant</li> <li>2. Clean the exchanger and improve the condensation condition</li> </ol>
The compressor suction pressure is too low	<ol style="list-style-type: none"> <li>1. Refrigerant is insufficient</li> <li>2. The filter and or capillary tube jam</li> <li>3. Water flow volume is insufficient</li> <li>4. Capillary tube of expansion valve</li> </ol>	<ol style="list-style-type: none"> <li>1.Check the leakage and add refrigerant</li> <li>2.Change the capillary tube or filter</li> <li>3.Clean the exchanger and improve the condensation</li> </ol>

## SWIMMING POOL HEAT PUMP

	<p>sensor bulb breakdown</p>	<p>condition 4.Change the expansion valve</p>
<p>The compressor suction pressure is too low</p>	<p>1. Refrigerant is insufficient 2. The filter and or capillary tube jam 3. Water flow volume is insufficient 4. Capillary tube of expansion valve sensor bulb breakdown</p>	<p>1.Check the leakage and add refrigerant 2.Change the capillary tube or filter 3.Clean the exchanger and improve the condensation condition 4.Change the expansion valve</p>
<p>Compressor can't work</p>	<p>1. Power failure 2. Compressor Control damaged 3. Wire loses 4. Compressor overload protection 5. Return water temperature setting incorrect 6. Water flow volume is insufficient</p>	<p>1.Check the power and solve the malfunction 2.Change Control 3.Check loose reason and repair 4. Compressor overload protection 5. Reset the return water temperature 6. Clean the water filer and exhaust the air from the system</p>
<p>Compressor noisy</p>	<p>1.Refrigerant enter into the compressor 2.Compressor damaged</p>	<p>1.Check the reason and solve the malfunction 2.Change the compressor</p>
<p>Fan can't work</p>	<p>1 Fan relay damaged 2.Motor is burnt out</p>	<p>1. Change the fan relay 2. Change the fan motor</p>
<p>The compressor run but no refrigeration</p>	<p>1. The refrigerant leak out 2. Plate exchanger freezes 3. Compressor failure</p>	<p>1.Check the leakage and add refrigerant 2.Check the reason and change the plate exchanger 3.Change the compressor</p>
<p>Low water temperature protection to the unit</p>	<p>1.Water flow volume is insufficient 2.Temperature Control setting is too low</p>	<p>1.Clean the water filter and exhaust the air from the system 2.Re-set</p>
<p>Few water flow volume protection to the unit</p>	<p>1.Water flow volume is insufficient 2.Flow switch</p>	<p>1.Clean the water filter and exhaust the air from the system 2.Change the flow switch</p>



# SWIMMING POOL HEAT PUMP

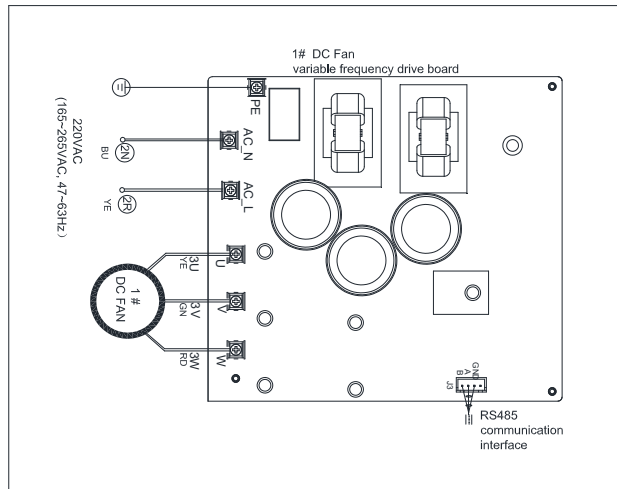
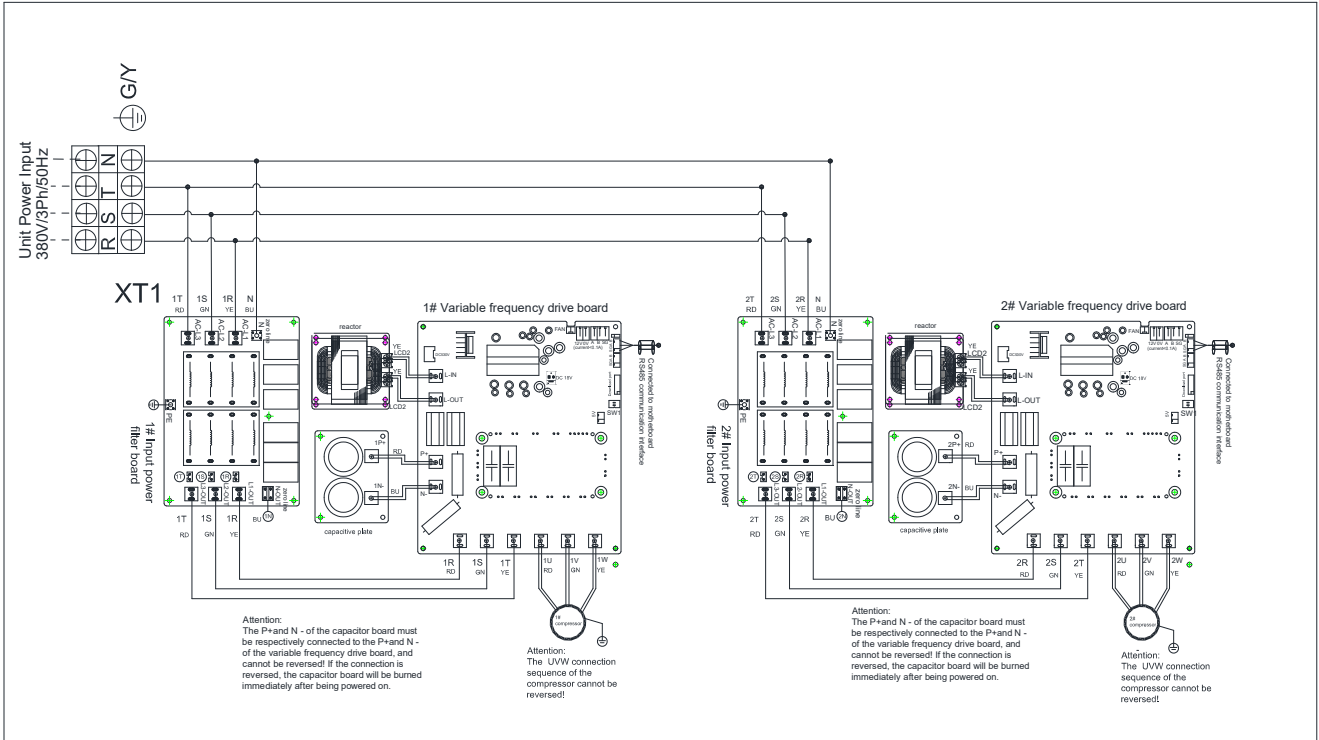



## DC INVERTER HEAT PUMP 130 KW



Manufacturer of pool equipments in Turkey  
netahavuz.com

[@/neta-havuz](#)

[@/neta.pool](#)

[f/NetaHavuzTürkiye](#)

[in/netahavuz](#)

[v/NetaHavuzTurkey](#)

Manufacturer: Neta Yapı Endüstri ve Tic. Ltd. Şti.

Address: Hüseyinli mah. Beykoz Cad. No: 151/A 34799 Çekmeköy İstanbul | Tel: +90 216 345 75 45 info@netahavuz.com | netahavuz.com